

Recent advances in direct solar thermal power generation

Yue-Guang Deng and Jing Liu^{a)}

*Technical Institute of Physics and Chemistry, Chinese Academy of Sciences, Beijing
100190, People's Republic of China*

(Received 14 April 2009; accepted 29 July 2009; published online 2 October 2009)

The recent energy crisis and environmental burden are becoming increasingly urgent and drawing enormous attention to solar-energy utilization. Direct solar thermal power generation technologies, such as thermoelectric, thermionic, magnetohydrodynamic, and alkali-metal thermoelectric methods, are among the most attractive ways to provide electric energy from solar heat. On the one hand, these methods have the potential to be more efficient than traditional ways since they can convert heat to electricity directly without experiencing the conventional intermediate mechanical energy conversion process; on the other hand, these electricity generators are generally silent, reliable, and scalable, making them very suitable to serve as a distributed power generation system for certain specialized fields, such as military and space applications. A lot of effort has been devoted to investigate the energy conversion theory and practical applications thus far. This paper is intended to present a thorough review on recent advances in developing the thermoelectric, thermionic, magnetohydrodynamic, and alkali-metal thermoelectric technologies for direct solar thermal power generation. Both the fundamental issues and latest application research are illustrated and critical issues are discussed. The paper concludes with a description of future developments expected in the subjects covered. © 2009 American Institute of Physics. [doi:10.1063/1.3212675]

NOMENCLATURE

η	Conversion efficiency
ρ	Specific electrical resistivity
σ	Electric conductivity
k_T	Specific thermal conductivity
T_h	Absolute hot-junction temperature
T_c	Absolute cold-junction temperature
V_T	Terminal output voltage
T	Mean absolute temperature
Z	Figure of merit
S	Seebeck coefficient
I	Output current
K	Load coefficient
u	Velocity
B	Magnetic induction intensity
MHD	Magnetohydrodynamic
TEG	Thermoelectric generator
TEC	Thermoelectric cooler
IGCC	Integrated coal gasification combined cycle
AMTEC	Alkali-metal thermoelectric converter

^{a)} Author to whom correspondence should be addressed. Electronic mail: jliu@mail.ipc.ac.cn. Tel.: +86-10-82543765. FAX: +86-10-82543767.

BASE	Beta alumina solid electrolyte
PTC	Parabolic trough concentrator
CPC	Compound parabolic concentrator
STG	Space solar thermoelectric generator
AU	Astronomical unit
TE-RSC	Thermoelectric roof solar collector
ACH	Air changes per hour
PV	Photovoltaic
SEPS	Space electric propulsion system
SHTTEC	Solar high-temperature thermionic energy converter
CIM	Cylindrically inverted multicell
HPALM	High-performance advanced low mass
CIC	Cylindrical inverted thermionic converter
LMMHD	Liquid metal magnetohydrodynamic

I. INTRODUCTION

Direct solar thermal power generation has been an attractive electricity generation technology using a concentrator to gather solar radiation on a heat collector and then directly converting heat to electricity through a thermal electric conversion element. Compared with the traditional indirect solar thermal power technology utilizing a steam-turbine generator, the direct conversion technology can realize the thermal to electricity conversion without the conventional intermediate mechanical conversion process. The power system is, thus, easy to extend, stable to operate, reliable, and silent, making the method especially suitable for some small-scale distributed energy supply areas. Also, at some occasions that have high requirements on system stability, long service life, and noiselessness demand, such as military and deep-space exploration areas, direct solar thermal power generation has very attractive merit in practice. At present, the realistic conversion efficiency of direct solar thermal power technology is still not very high, mainly due to material restriction and inconvenient design. However, from the energy conversion aspect, there is no conventional intermediate mechanical conversion process in direct thermal power conversion, which therefore guarantees the enormous potential of thermal power efficiency when compared with traditional indirect solar thermal power technology.

Direct thermal electric conversion methods as applied in solar thermal power generation field mainly includes thermoelectric conversion, thermionic conversion, alkali-metal thermoelectric conversion, and magnetohydrodynamic (MHD) power generation.¹ Among them, the thermoelectric conversion is based on the Seebeck effect, where electromotive force is generated due to the temperature difference between the two ends of thermoelectric couples consisting of *n*-type and *p*-type thermoelectric elements. The thermionic conversion is based on thermionic emission phenomenon which means that under high temperature, electrons will emit from the metal surface. The alkali-metal thermoelectric conversion mainly generates current through the selective permeation of beta alumina solid electrolyte (BASE), which sodium ions can go through while the electrons cannot. The MHD power generation is based on Faraday's law of electromagnetic induction. That is, when conductive fluid flows through, the magnetic field ions will move in the direction perpendicular to both magnetic field and flow direction and then an electromotive force will arise. A brief introduction on these four direct thermal electric conversion technologies follows.

A. Thermoelectric technology

Thermoelectric conversion is a Seebeck effect-based technology which can directly convert thermal energy to electricity through thermoelectric elements. A typical schematic model is shown in Fig. 1(b). By combining one end of two different semiconductors (*n* type and *p* type), putting it at high temperature, and making the other end open circuit and under low temperature conditions, an open-circuit voltage will be generated at the cold end. A commercial thermoelectric

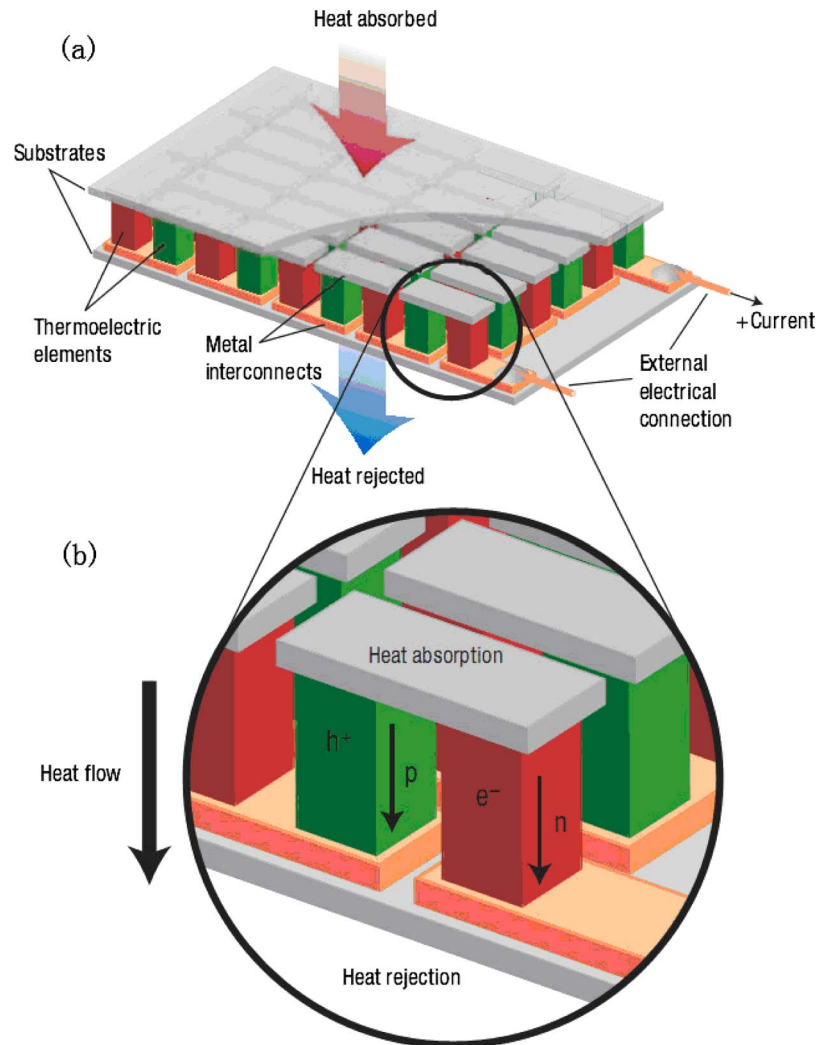

FIG. 1. The schematic view of (a) thermoelectric device and (b) thermoelectric couple. Reprinted with permission from G. J. Snyder and E. S. Toberer, *Nature Mater.* 7, 105 (2008). Copyright © 2008, Nature Publishing Group.

generator (TEG) generally contains hundreds of thermoelectric couples, which are connected electrically in series and thermally in parallel. The structure is shown in Fig. 1(a).

In general, the optimum thermoelectric conversion efficiency depends on the device figure of merit [defined in Eq. (2)] and the temperature difference between the two ends of the TEG. The conversion efficiency would be higher with a larger temperature difference and a greater device figure of merit. The relationship can be expressed as³

$$\eta = \frac{T_h - T_c}{T_h} \frac{\sqrt{1 + ZT} - 1}{\sqrt{1 + ZT + T_c/T_h}}, \quad (1)$$

$$Z = \frac{S^2}{\rho k_T}, \quad (2)$$

where η is the optimum efficiency, T_h is the absolute hot-junction temperature, T_c is the absolute cold-junction temperature, T is the mean absolute temperature, Z is the figure of merit, S is the Seebeck coefficient which is used to quantitatively describe the magnitude of generated thermo-

electric voltage in response to the temperature difference, ρ is the specific electrical resistivity, and k_T is the specific thermal conductivity. As can be seen, the optimum efficiency of a thermoelectric converter is thermodynamically limited by the Carnot efficiency like all heat engines. To improve thermoelectric conversion efficiency, it should not only produce a larger temperature difference between the two ends of TEG but also tune the thermoelectric materials to have a large Seebeck coefficient, a large electrical conductivity, and a small thermal conductivity within the temperature range.

At present, the thermoelectric conversion efficiency of TEG devices is still relatively low (generally reaches 5%),⁴ while the predicted maximum conversion efficiency of a segmented thermoelectric unicouple using advanced materials can achieve 15% for a hot-side temperature of 975 K and a cold-side temperature of about 300 K.⁵ In order to enhance the thermoelectric conversion efficiency for both device and system, a lot of effort has been under way from the following four aspects:^{6,7}

- (1) Maximizing the temperature difference between two sides of TEG devices by increasing the heat flow through thermoelectric devices with methods such as raising the solar concentration ratio.
- (2) Enhancing material thermoelectric characteristic. Seeking more suitable thermoelectric materials, such as nanometer materials, is the most useful and effective way to improve thermoelectric conversion efficiency at present.
- (3) Implementing effective heat dissipation on the cold side, so that thermoelectric materials can work in the most suitable temperature range.
- (4) Carrying out design optimization and computer simulation to optimize the structure of thermoelectric elements and improve the packaging technology of devices.

B. Thermionic technology

Thermionic conversion is based on thermionic emission phenomenon which means under high temperature electrons will evaporate from the metal surface. A simple thermionic converter consists of an emitter and a collector close to each other. When the emitter (cathode with high work function) is heated, the electrons will emit from the metal surface and be received by the collector (anode), so current can be generated when using electrical load to connect the emitter and collector. The schematic view of a thermionic converter is shown in Fig. 2.

The thermionic conversion efficiency is much higher than thermoelectric conversion and can exceed 30%.^{8,9} However, it should work at relatively high temperatures. Generally, the emitter temperature could work around 2000 K. The ideal efficiency of a thermionic converter can be expressed as¹⁰

$$\eta = \frac{IV_T}{Q_E + [Q_L - (Q_d/2)] + (Q_r + Q_k)}, \quad (3)$$

where I is the output current, V_T is the terminal output voltage, Q_E is the energy transferred from the emitter by means of electrons flowing into and out of the emitter, Q_L is the energy transferred from the emitter by means of heat conduction through the electrical leads, Q_d is the Joule heat generated in the electrical leads, Q_r is the energy transferred from the emitter by means of thermal radiation, and Q_k is the energy transferred from the emitter by means of heat conduction through the structure component.

It is seen from Eq. (3) that the ideal thermionic conversion efficiency is mainly affected by the following three types of processes:¹⁰

- (1) Electronic processes. It is known that the electron emission effect has a great impact on I , V_T , and Q_E . The stronger the electron emission effect, the higher I , V_T , and Q_E will be, so the conversion efficiency would be increased. Generally, there are three ways to improve the thermionic electron emission, including enhancing material thermionic characteristic, minimizing the distance between two electrodes, and introducing positive cesium ions to neutral-

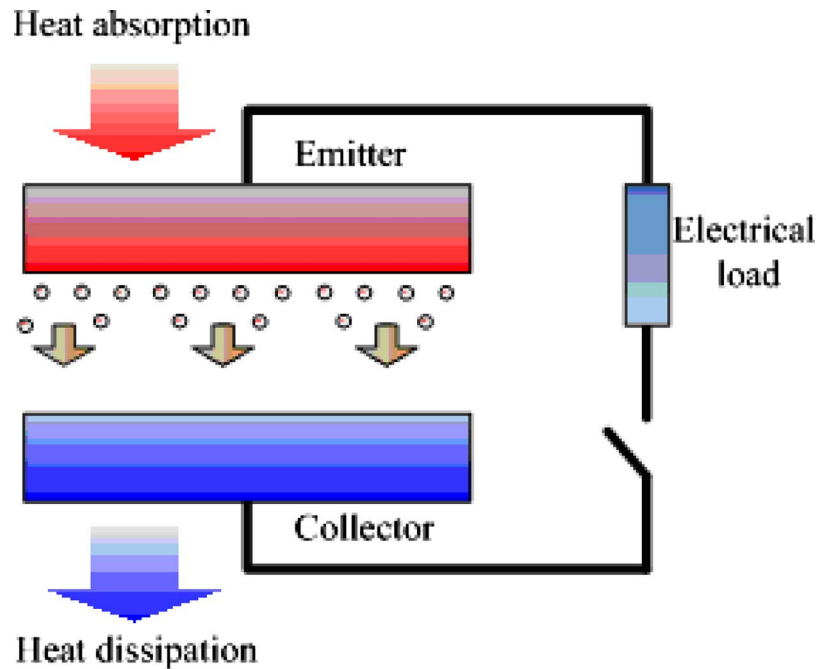

FIG. 2. The schematic view of a thermionic converter.

ize the space charge effect (the space charge effect refers to the emitted electrons in the interelectrode region that would preclude the subsequent electron emission of the cathode, so the cesium vapor is introduced and stored between the cathode and anode to neutralize the space charge effect).

- (2) Electrical lead processes. The electrical leads processes are represented by V_T and $Q_L - (Q_d/2)$. On the one hand, the output voltage would be partly loaded on the electrical lead resistance, resulting in reduced output power. On the other hand, heat conduction through the electrical leads will lose part of useful heat energy. Therefore, these two effects would result in a lower conversion efficiency.
- (3) Interelectrode radiation and heat-conduction processes. These effects are mainly reflected by $Q_r + Q_k$ and are always unavoidable and have a poor impact on thermionic conversion efficiency. Design optimization and packaging improvement technology can effectively reduce these effects.

Research on thermionic converters is carried out along two directions:¹¹

- (1) Increase the conversion efficiency in the general emitter temperature and
- (2) Decrease the emitter operating temperature when efficiency is ensured, so as to enlarge the thermionic application fields.

C. Magnetohydrodynamic technology

MHD power generation is based on Faraday's law of electromagnetic induction. When conductive fluid flows through a magnetic field that is perpendicular to the flowing direction, it will cut the magnetic lines and then the electromotive force is induced in the direction perpendicular to both magnetic field direction and flow direction,¹² as shown in Fig. 3.

MHD power generation can be classified on the basis of working fluid as gaseous plasma MHD power generation and liquid metal MHD power generation. Gaseous plasma-based MHD generator generally requires a relatively high operating temperature to ensure the gas has a reasonable value of electrical conductivity. Also, the flow speed should be fast enough to achieve

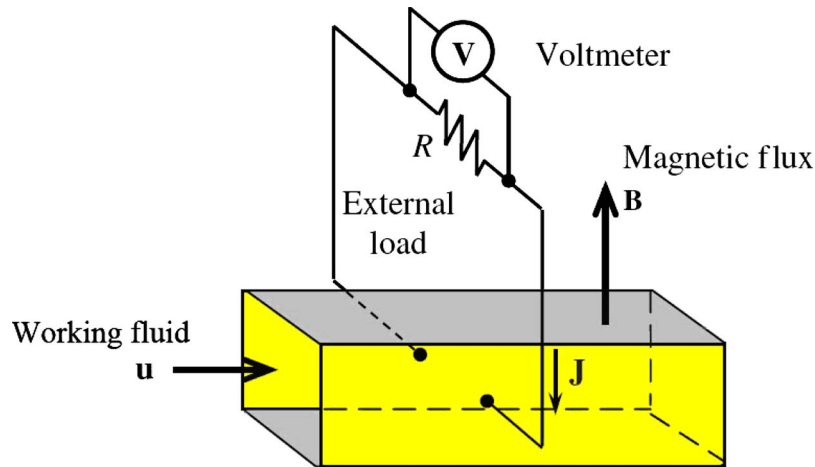

FIG. 3. The schematic view of MHD power generation. Reprinted with permission from H. Yamaguchi, X. R. Zhang, S. Higashi, and M. J. Li, *J. Magn. Magn. Mater.* **320**, 1406 (2008). Copyright © 2008, North-Holland.

relatively high-power output and efficiency. The liquid metal MHD power generation can be operated in relatively low temperature, pressure, and flow speed since liquid metal has a much higher electrical conductivity than gaseous plasma. However, liquid metal is generally expensive, so the closed-cycle system must be adopted and the working fluid should be recycled again after passing through the magnetic field.^{13,14} One of the typical structures of solar MHD power generation is shown in Fig. 4.

The MHD power generation system has high efficiency. This is because the power generation system can work over a high temperature range of 600–3000 °C.^{13,16} Therefore, it can utilize a conventional steam-cycle power system as the second stage, so as to achieve higher power output and improve the overall electricity generation efficiency.¹³ Without taking into account the electric leakage, Hall effect, and other influence factors, the power density of MHD power generator can be simply expressed as¹⁴

$$P = K(1 - K)\sigma u^2 B^2, \quad (4)$$

where K is the load coefficient which means the ratio of load resistance to the total resistance, σ is the electric conductivity of working fluid, u is the velocity of fluid, and B is the magnetic induction intensity. It can be seen from Eq. (4) that, to increase the output power density, the

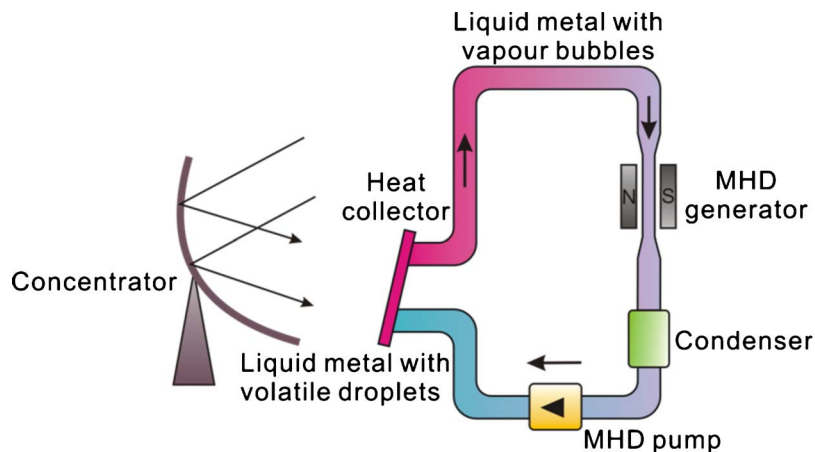

FIG. 4. Schematic of a typical solar-assisted liquid metal MHD power generation system (Ref. 15).

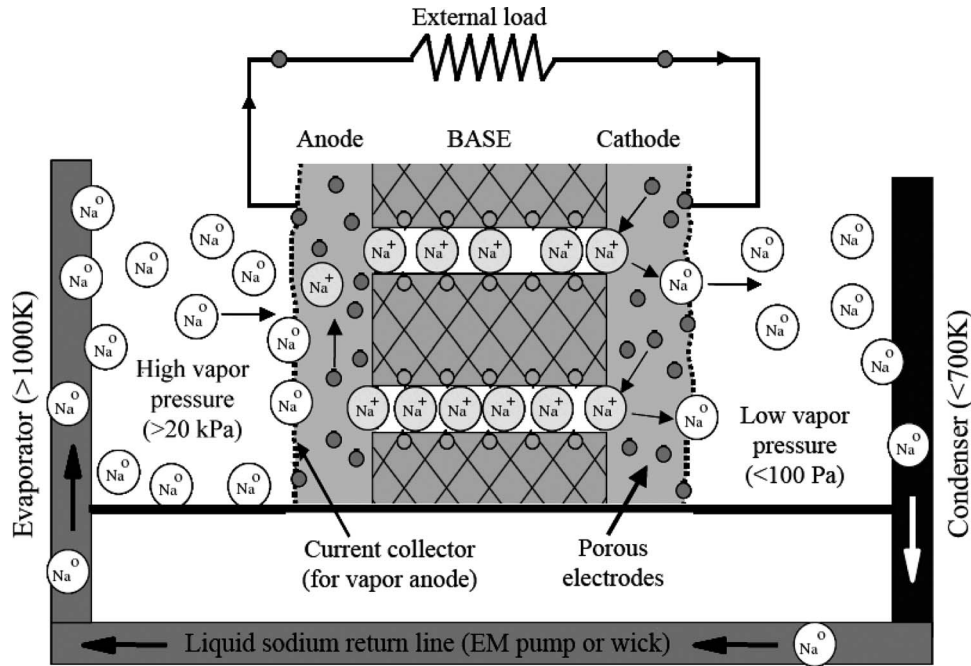

FIG. 5. Schematic view of AMTEC. Reprinted with permission from M. S. El-Genk and J. M. P. Tournier, *Energy Convers. Manage.* **45**, 511 (2004). Copyright © 2004, Pergamon.

working fluid should have high electric conductivity and high flow velocity and the system must have high magnetic induction intensity.

Although the efficiency of the MHD power generation is only about 20%, when it combines with a gas turbine or steam-turbine power system to make up a cascade power system, the overall efficiency can exceed 50%.¹⁶ This MHD topping combined power generation system could be superior to integrated coal gasification combined cycle when it has good design and optimization.¹⁷ Therefore, MHD power generation is a very promising direct solar thermal power generation technology.

D. Alkali-metal thermoelectric technology

Alkali-metal thermoelectric converter (AMTEC) is a kind of direct thermal electric energy conversion element, using BASE as ion selective permeation layer and alkali metal as working fluid, when the working temperature range is about 1000–1200 K at the hot side. Theoretically, the thermoelectric conversion efficiency can reach 20%–40%.¹⁸

The schematic view of AMTEC is shown in Fig. 5. The AMTEC is divided into two parts with different pressures by BASE. The high-pressure side is filled with sodium metal under the temperature maintaining at 900–1300 K, and the low-pressure side keeps it at 400–700 K. The surface of the low-pressure side of the BASE is covered with porous metal electrode (cathode) while the other side in the high pressure-temperature region is covered by the anode surface. External load is connected between the cathode and anode at the two sides of BASE which therefore enables the circulation of electrons.¹⁹

When the system is operating, sodium would be ionized in the high pressure-temperature area. While the electrons cannot pass through an alumina solid electrolyte, the sodium ions can go through the BASE and meet the electrons circulated through the external loads to recombine the neutralized sodium in the low-pressure side of BASE. After that, the neutralized sodium would be cooled by the condenser and returned to the high-pressure evaporator region through an electromagnetic pump or a porous capillary wick to circulate again.¹⁹

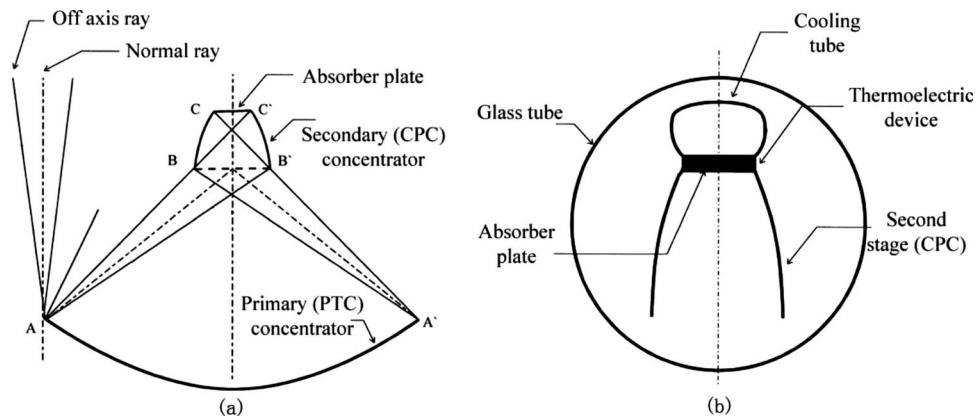

FIG. 6. Schematic view of (a) two-stage concentrator and (b) receiver system. Reprinted with permission from S. A. Omer and D. G. Infield, *Energy Convers. Manage.* **41**, 737 (2000). Copyright © 2000, Pergamon.

The theoretical efficiency of AMTEC could be 30%–40%, but the actual efficiency is only 10%–15%.²¹ Some typical approaches to improve the thermoelectric conversion efficiency of AMTEC were proposed by Zhang and Li,²² which include

- (1) Optimizing structure design and reducing system heat radiation and conductive loss as much as possible;
- (2) Seeking for excellent electrode materials and better fabrication techniques for porous metal electrode, so as to improve the output current density and reduce the polarization effect of electrodes;
- (3) Substituting sodium with kalium as the working fluid under certain conditions (however, proper system design and suitable working conditions are very important because some problems, such as dryout in the evaporator wick, could more easily happen for kalium-based AMTEC);²³ and
- (4) Raising the temperature of the AMTEC high-temperature side (however, the temperature should not be too high since the degradation of the electrode material would happen under a high temperature).

II. ADVANCES IN DIRECT SOLAR THERMAL POWER GENERATION

Solar radiation covers vast areas and can have especially high heat flux after being concentrated. Therefore, it could achieve a flexible power generation with nonpollution, high efficiency, and high safety and reliability characteristics when combined with direct thermal electric conversion technologies. In this section, research and recent advances on direct thermal electric conversion technology based on solar power will be reviewed and discussed.

A. Solar thermoelectric power generation

Generally speaking, a typical solar thermoelectric power generation system would consist of a concentration system, heat receiver, thermoelectric converter, and heat dissipation module. Hiroyuki and Akira²⁴ presented a typical solar thermal power generating system, which comprised a light collecting optical system, a heat storage layer, a thermoelectric conversion layer, and a heat-exchanging layer. This system was supposed to be inexpensive, highly reliable, highly safe, and also suitable for a small size power generation system. However, the efficiency of the system should be carefully evaluated. Omer and Infield²⁵ illustrated a design procedure and thermal performance analysis of a solar combined heat and thermoelectric power cogeneration system based on a two-stage solar-energy concentrator. As can be seen in Fig. 6, the two-stage concentrator comprised a one axis parabolic trough concentrator and a second stage compound parabolic concentrator to further concentrate solar radiation. The hot side of a thermoelectric device was

attached to the absorber plate to receive the heat energy, while the cold side was attached to the cooling tube so as to extract the waste heat and maintain a suitable working temperature for the thermoelectric device. This design could provide a wider receiver than usual and allow interception of incoming rays within a certain angular region. Computational fluid dynamic modeling and laboratory-scale experiment were used to assess the designed system. The results showed that efficiency was very sensitive to the collector tracking misalignment angle, and the system could tolerate misalignment angles as high as 4° without significant thermal performance decrease.

System-level theoretical analysis of solar thermoelectric generation is of great use and can give important theoretical support for developing practical applications. Chen²⁶ established a thermodynamic model to investigate the optimal performance of a solar TEG. In the model, four irreversibilities including finite-rate heat transfer between the thermoelectric devices and the external heat reservoirs, heat leak via the thermoelectric devices, Ohmic heat production inside the thermoelectric devices, and heat loss in the solar collector were taken into consideration. Some important theoretical results, such as the efficiency upper bound of solar TEGs, optimal operation temperature of solar collectors, maximum power output, and optimal load matching, were determined. The results are meaningful and could offer theoretical support for experimental investigation of solar-driven TEGs.

Solar thermoelectric generation is a significant option for space power supply. In the work of Lenoir *et al.*,²⁷ the skutterudite thermoelectric materials were proposed for space solar TEG. Additionally, two space solar thermoelectric generator (STG) concepts, namely, the flat plate configuration with identical collector and radiator areas which had a relatively small area and low mass and the STG configuration with concentrators which had high concentration coefficient, were considered suitable for the space requirement. The theoretical comparison and discussion about the electrical performance as a function of sun-spacecraft distance of these two concepts were performed. The results showed that the output power higher than 400 W could be achieved when the distance was smaller than 0.45 AU. However, if the spacecraft moved to 0.30 AU, the collector temperature would increase up to 1000 K, which might exceed the allowable temperature range of skutterudite thermoelectric materials. Therefore, the sun-spacecraft distance greatly affects power generation and reasonable protection is needed to maintain the temperature within the allowable range.

Solar thermoelectric technology can also be used to improve the indoor environment and save building energy consumption. Maneewan *et al.*^{28,29} performed a numerical and laboratory-scale investigation on attic heat gain reduction by means of thermoelectric roof solar collector (TE-RSC). The system is shown in Fig. 7. Due to the incident solar radiation, the thermoelectric modules had a temperature difference between its hot and cold sides and generated direct current to drive a ventilating fan for cooling the TE-RSC and achieving better indoor ventilation so as to reduce ceiling heat gain. The analytical result showed that the decrease in the roof heat gain of 25%–35% and the corresponding induced air change rate of about 20–45 ACH (air changes per hour) could be achieved. According to the economical analysis, the annual electrical energy saving was about 362 kW h and the payback period was about 4.36 years. When compared to commercial insulations, although the ceiling heat transfer reduction in commercial insulations was relatively higher, the initial cost of TE-RSC was lower than microfiber or radiant barrier insulations by about 50% and 27%, respectively. Therefore, the TE-RSC system is an attractive option by reason of its relatively low initial cost and simplicity.

Using solar TEG to power the thermoelectric cooler (TEC) could achieve a completely self-sustained cooling system. The optimal operation of solar-based TEG-TEC system was evaluated by Khattab and El Shenawy.³⁰ The schematic of the system with solar reflectors is shown in Fig. 8. A mathematical model simulating the TEG-TEC system was established based on the conventional theory and experimental data of commercially available TEGs and TECs. The results showed that five thermocouples of the TEG could drive one thermocouple of the TEC under the actual climatic conditions of Cairo, and ten of the used TEGs were required to achieve optimum

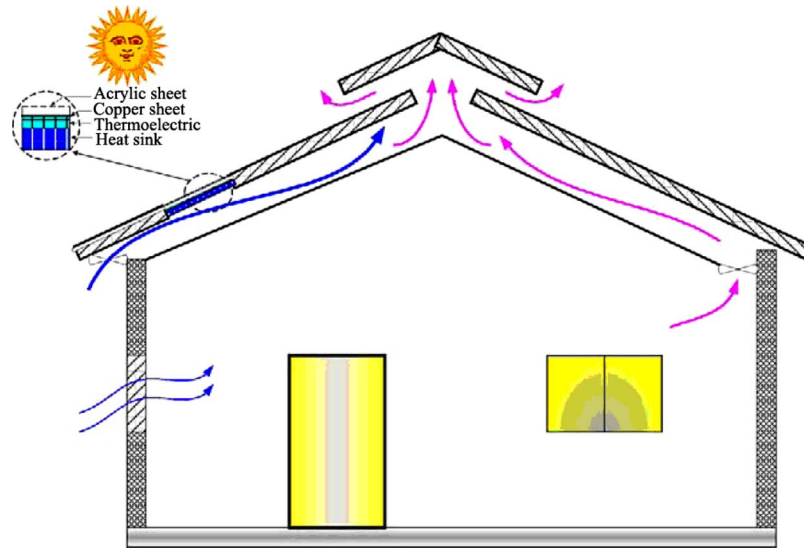

FIG. 7. Schematic of the TE-RSC power generator. Reprinted with permission from S. Maneewan, J. Khedari, B. Zeghamati, J. Hirunlabh, and J. Eakburanawat, *Renewable Energy* **29**, 743 (2004). Copyright © 2004, Pergamon.

performance of the used TEC during most times of the year. However, this result might not be suitable for other conditions, since the system performance significantly depends on the device structure design and working environment.

It is well known that photovoltaic (PV) cells can only convert a small portion of solar energy into electric power, and a large amount of remaining solar radiation mainly produces heat energy. Therefore, a lot of effort has been expended to combine the PV and thermoelectric technology in an efficient and powerful way. Most of these inventions are focused on the structure design.³¹⁻³³ Micallef³¹ presented a Seebeck solar cell device, in which the materials used to form conductors in the *n*-type and *p*-type regions of the cells were chosen for their different thermoelectric char-

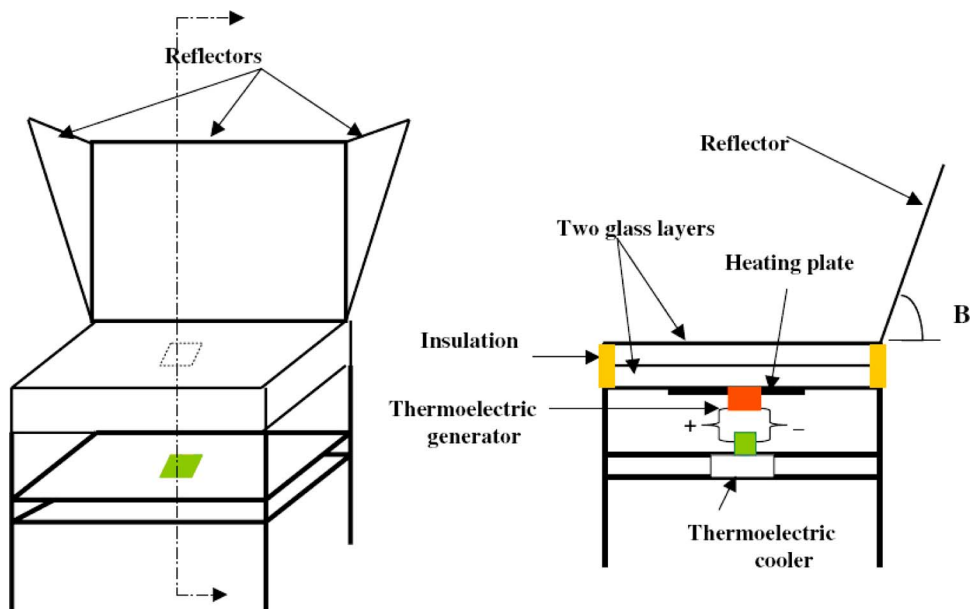

FIG. 8. Schematic of the TEG-TEC system with solar reflectors. Reprinted with permission from N. M. Khattab and E. T. El Shenawy, *Energy Covers. Manage.* **47**, 407 (2006). Copyright © 2006, Pergamon.

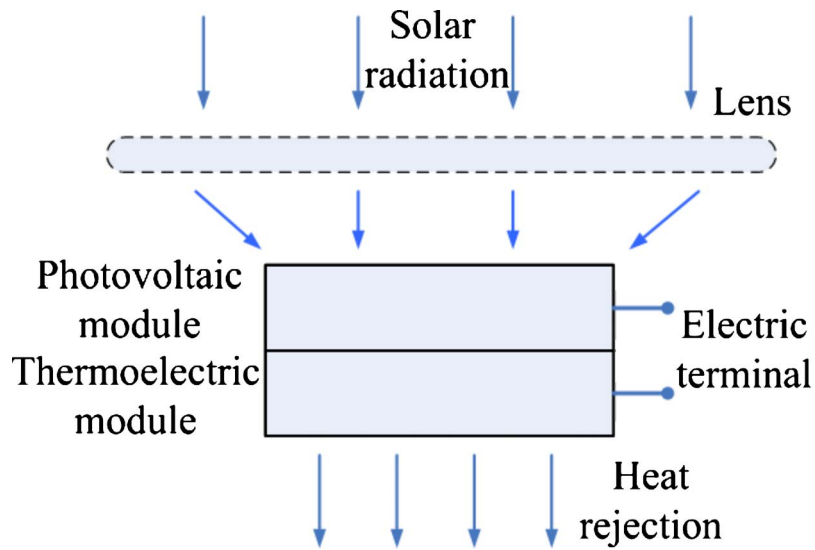

FIG. 9. Simple structure combining PV and thermoelectric conversion (Ref. 33).

acteristics. Therefore, electric power could be produced not only from the PV cells but also from the temperature gradient in the conductors resulting from solar radiation and waste heat generated in the PV cell. Multiple devices could be connected in series or parallel so as to enhance the output power. Hunt³³ presented a simple hierarchical structure, which had at least one thermoelectric module thermally attached to the PV module and could produce electricity both from the PV cell and thermoelectric module. This simple structure combining both PV and thermoelectric conversion is shown in Fig. 9.

Hecht³⁴ proposed another solar-energy conversion package which combined PV cell, thermoelectric conversion unit, and thermal heating system together. One of its embodiments is shown in Fig. 10. Unlike the system described previously, the thermoelectric cell and PV cell in this system were separated, and the irradiated surface of the PV cell was treated with selective spectrum

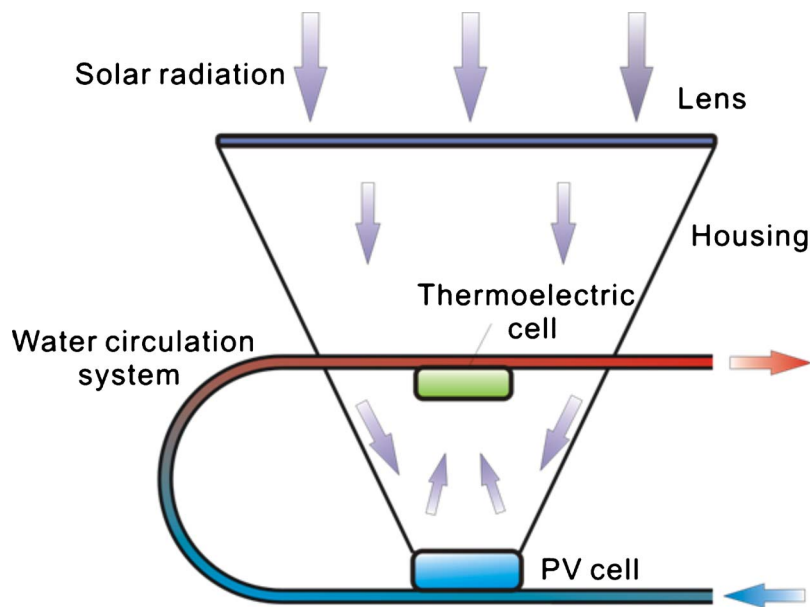

FIG. 10. Separated structure combining PV and thermoelectric conversion (Ref. 34).

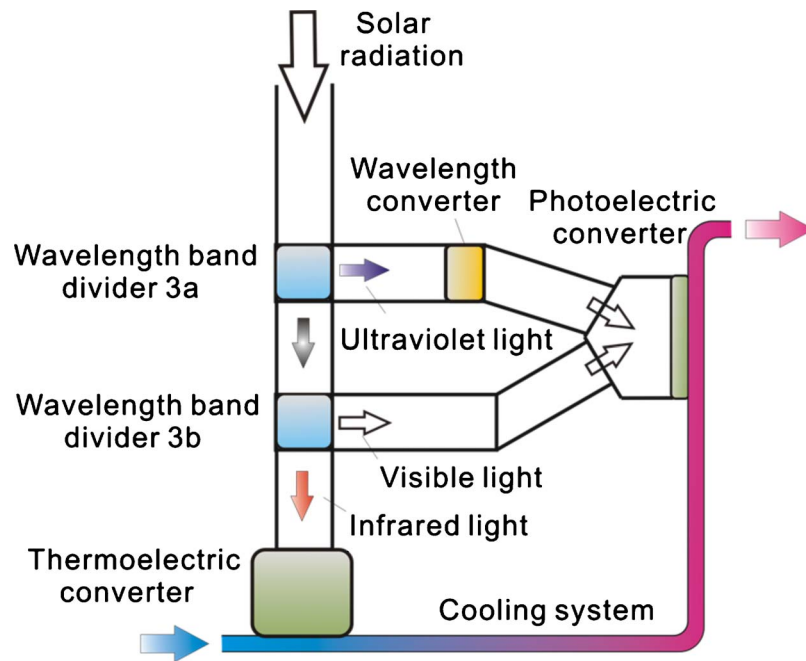

FIG. 11. Combined system utilizing wavelength band divider (Ref. 35).

reflective coating to allow high conversion PV wavelength energy to be absorbed by the PV cells, while the rest of less effective wavelength radiation would be reflected to the thermoelectric cell surface to produce electricity from heat; therefore higher efficiency could be achieved.

Apart from that, making full use of solar radiation can also be achieved by performing a wavelength band division of solar light.³⁵ In Fig. 11, the introduced solar radiation could be divided by wavelength band dividers 3a and 3b. At first, the ultraviolet light would be separated by the wavelength band divider 3a and reach the wavelength converter to be converted into visible light. Then the rest of solar radiation would pass through the wavelength band divider 3b to be divided into visible light and infrared light. After these wavelength band division processes, the visible light would reach the photoelectric converter where it could be converted into electric energy, and the infrared light would be converted by a thermoelectric converter into electric energy through thermal energy. Therefore, more efficient solar-energy utilization can be achieved using this compound system.

Finally, thermoelectric material which greatly affects the efficiency is of huge importance for solar thermoelectric power generation. Apart from the large Seebeck coefficient, good electrical conductivity, and small thermal conductivity, the thermoelectric materials must present excellent thermal and chemical stability at high temperature when used under the concentrated solar radiation. A great deal of research on thermoelectric material has been conducted over the past 50 years, and the literature is rich.^{2,36,37} Therefore this part is not described in further detail.

B. Solar thermionic power generation

Most of the recent research on solar thermionic power generation focuses on the application field of space travel energy source.³⁸ Ogloblin *et al.*³⁹ presented a thermionic-based solar bimodal space electric propulsion system (SEPS), which had the capability to generate both direct thermal propulsion and electric energy. The solar high-temperature TEC used in the system was a planar diode operating in the Cs–Ba Knudsen mode. The thermionic energy converter could work with emitter temperature around 2500 K and has an efficiency of about 25%. The schematic of the SEPS is shown in Fig. 12. It can be seen that solar radiation was delivered into the heat-exchanger

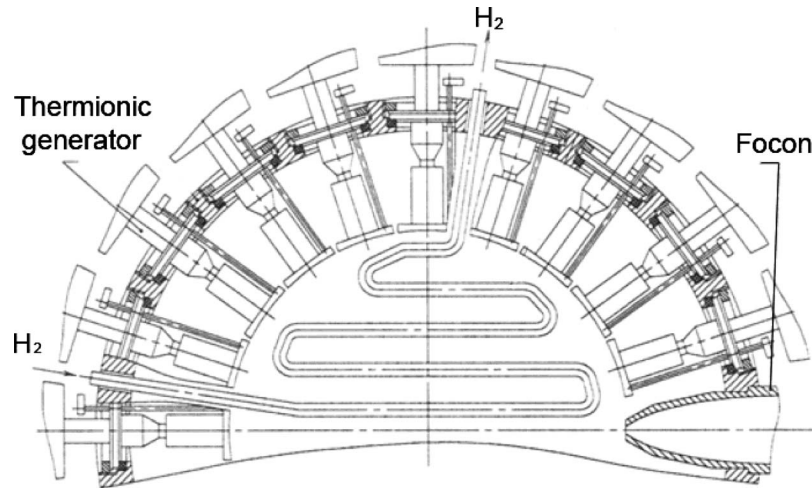

FIG. 12. Schematic of thermionic-based solar bimodal SEPS. Reprinted with permission from B. G. Ogloblin, E. Y. Kirillov, A. V. Klimov, A. I. Shalaev, D. P. Shumov, A. Y. Ender, V. I. Kuznetsov, and V. I. Sitnov, *Space Technology and Application International Forum* (Albuquerque, 1996). Copyright © 1996, American Institute of Physics.

cavity through the focon, and the thermionic emitters composed the inner surface of the cavity. When using an auxiliary concentration system as the focon, the emitters could be heated to 2600 K, therefore producing sufficient electric energy efficiently.

Generally speaking, there are two types of thermionic converters used in space field: planar converter as discussed previously and cylindrical converter. Planar converters generally have a small emitter area and consequently have a relatively small power output, while cylindrical converters, particularly multicell devices, have large emitters so that greater output power can be achieved.⁴⁰ Therefore, a cylindrical converter is more suitable when greater output power and convenient design are required. Martinez *et al.*⁴¹ presented a detailed design and fabrication process of a cylindrically inverted multicell thermionic converter for solar power and propulsion systems. The thermionic converter consisted of four polycrystalline rhenium (Re) emitters, a cesium (Cs) containment vessel, and a collector trilayer, which was made up of a niobium alloy base tube, plasma sprayed aluminum oxide insulation layer, and a niobium collector tube. The converter was expected to produce 454 W of power with a current of 160 A under a peak efficiency of 12.5%. The schematic of high-performance advanced low mass (HPALM) solar space power system based on thermionic conversion is shown in Fig. 13.

In space application fields, except for the efficiency and power output, the specific mass (W/kg) and stowed specific volume (kW/m^3) are very important metrics to determine the attractiveness of a power system. Streckert *et al.*⁴² presented a conceptual design of a solar space power system based on thermionic conversion, where advantages such as higher specific mass and stowed specific volume were illustrated. In this system, solar energy was collected by a two-stage concentrator system. A cylindrical inverted multicell thermionic converter was adopted since the thermal insulation procession was much easier and heat loss could be effectively reduced. The heat balance analysis showed that the solar thermionic system could produce 50 kW electric energy from the 950 kW solar radiation with an overall system efficiency of 5.3%. Although it might not match the efficiency of a solar-PV system, the specific mass and stowed specific volume were much higher than those of the present PV system. Moreover, the thermionic system was more compact and could operate at a very high temperature, so it was much easier to avoid the attack of pellets and laser weapons. However, the heat rejection temperature of thermionic converter was about 1000 K, so cascading thermionic with another low temperature power generation system such as thermoelectric, Stirling, or AMTEC was suitable and much higher efficiency could be achieved. Therefore, the solar thermionic power system is very attractive for use as the space travel energy source.

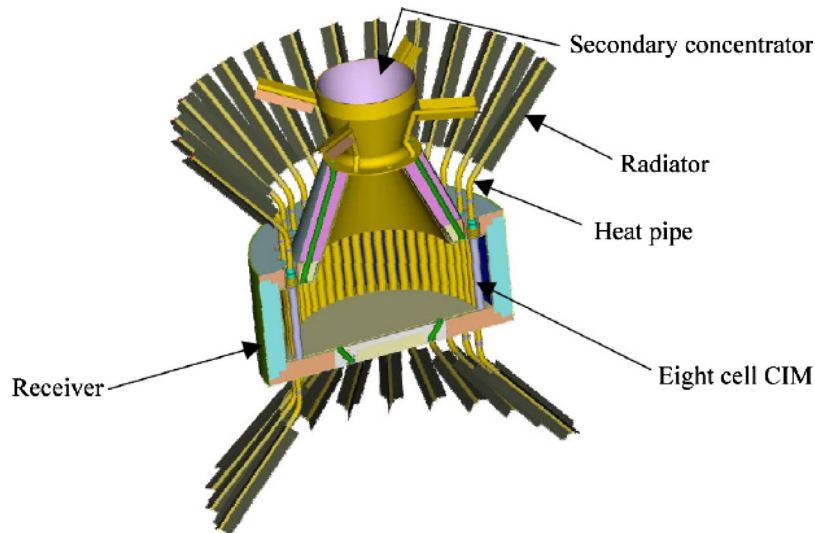

FIG. 13. Schematic of HPALM solar space power system, Reprinted with permission from M. R. Martinez, O. Izhvanov, B. Robertson, P. N. Clark, H. H. Streckert, and J. L. Desplat, Space Technology and Application International Forum (Albuquerque, 2005). Copyright © 2005, American Institute of Physics.

Solar light illumination could also have some positive effect on thermionic converter output characteristics and the effect was investigated in Refs. 43 and 44. Zheng *et al.*⁴³ found that the illumination could result in the effective ionization and excitation of cesium atoms, and so accelerate the transition to the ignited mode and/or increase the thermionic output current. If (1) space charge neutrality $\alpha < 10^{-2}$, (2) thermionic electron current density $J_e > 10^{-3}$ A/cm², and (3) emitter work function $\Phi_E > 2.2$ eV, the solar illumination could improve the thermionic performance and generate higher efficiency. Therefore, by utilizing this effect efficiently, better performance of solar thermionic power generation might be achieved.

Real on-sun experiments of thermionic converter under high solar flux are very important to determine the typical performance of solar thermionic power generation. Experiments on the cylindrical inverted thermionic converter were conducted by Clark *et al.*⁴⁵ The actual single cell cylindrical inverted converter and the schematic of the experimental platform are shown in Figs. 14 and 15, respectively. It can be seen that a primary mirror reflected and concentrated the solar flux to the thermal receiver, where a second concentrator was used to reduce reradiation losses and disperse the solar radiation within the receiver effectively. Since the weather was not ideal for sufficient solar irradiance, the emitter temperature reached only 1670 K when solar irradiance peaked at 830 W/m². Nevertheless, electric power was produced and the maximum output power

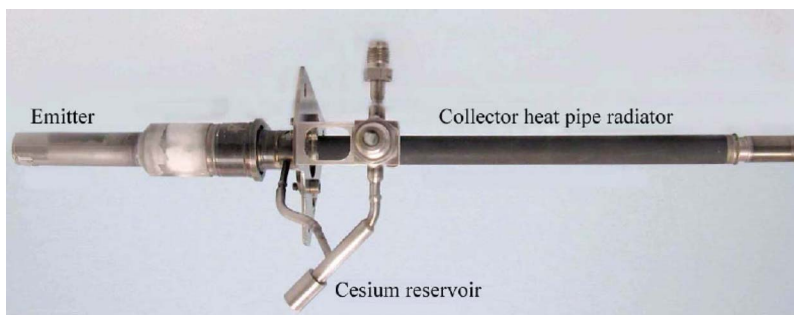

FIG. 14. Single cell cylindrical inverted converter. Reprinted with permission from P. N. Clark, J. L. Desplat, H. H. Streckert, S. F. Adams, and J. W. Smith, Space Technology and Application International Forum (Albuquerque, 2006). Copyright © 2006, American Institute of Physics.

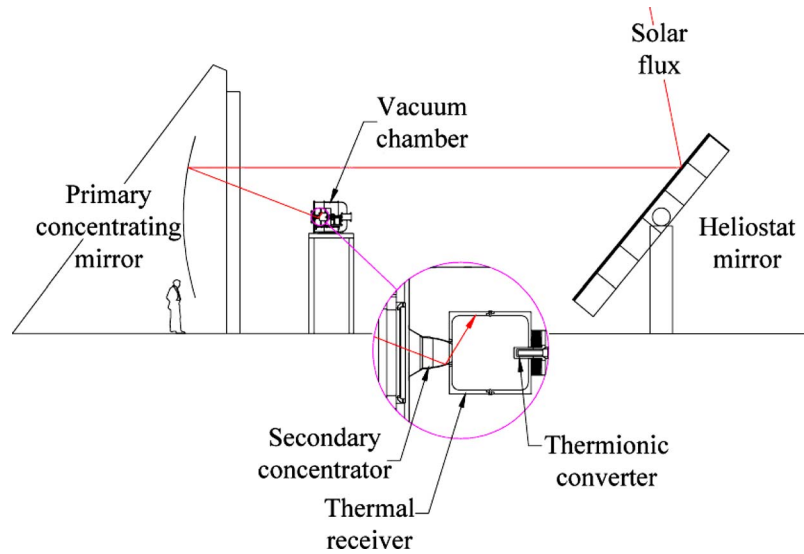

FIG. 15. The schematic of experimental platform. Reprinted with permission from P. N. Clark, J. L. Desplat, H. H. Streckert, S. F. Adams, and J. W. Smith, Space Technology and Application International Forum (Albuquerque, 2006). Copyright © 2006, American Institute of Physics.

was about 30 W. However, this result was far from its potential and could only show the feasibility of using solar thermionic converters to produce electrical power for future satellite power needs. Better design and improvement of experimental conditions are required to achieve the desired performance in the future.

Apart from being used in space fields, solar thermionic technology is also applicable for developing inexpensive and highly efficient terrestrial solar power systems. Ender *et al.*⁴⁶ described such an environmentally friendly terrestrial solar cogeneration system based on a Cs–Ba thermionic converter. In Fig. 16, the cascade solar power system had a Cs–Ba thermionic converter as the high temperature stage and added another lower temperature dynamic or thermoelectric conversion as the second stage to achieve higher efficiency of the whole system. In order to reduce the radiation loss of the receiver, a two-stage solar concentrator with a parabolic mirror as a first stage and focus as the second was proposed. The analytical result showed that the cascaded solar power system could produce about 1 kW electric power with an overall efficiency of 32% under the two-stage conversion. When taking into account the utilization of hot water, the thermal efficiency could approach 90%. Therefore, solar thermionic technology is very attractive for terrestrial use.

As in the prior compound thermoelectric discussion, combining thermionic with other power generation methods can have higher conversion efficiency. A solar powered thermionic-photoelectric power generator which utilizes both thermionic and photoelectric technologies was described by Fowler and Israel.⁴⁷ A preferred cathode metal, such as thoriated tungsten, was chosen for its excellent characteristics in both thermionic and photoelectric emission performance. In order to increase the overall efficiency, an appropriate light amplification method was utilized to enhance the photoelectric emission effect and increase the output current by shifting a portion of the incident light spectrum toward the ultraviolet region. Moreover, the radiation pressure of light was used to sweep away the space charge of electrons and enhance the electric generation efficiently. Therefore, this compound invention is very attractive for its higher current generation capability when compared with an individual system.

From this discussion, it can be seen that although the thermionic conversion efficiency is high in some literature, the real on-sun experiments in other research indicate that the overall solar thermionic conversion efficiency does not exceed 10%,³⁸ which is partly because of weather,

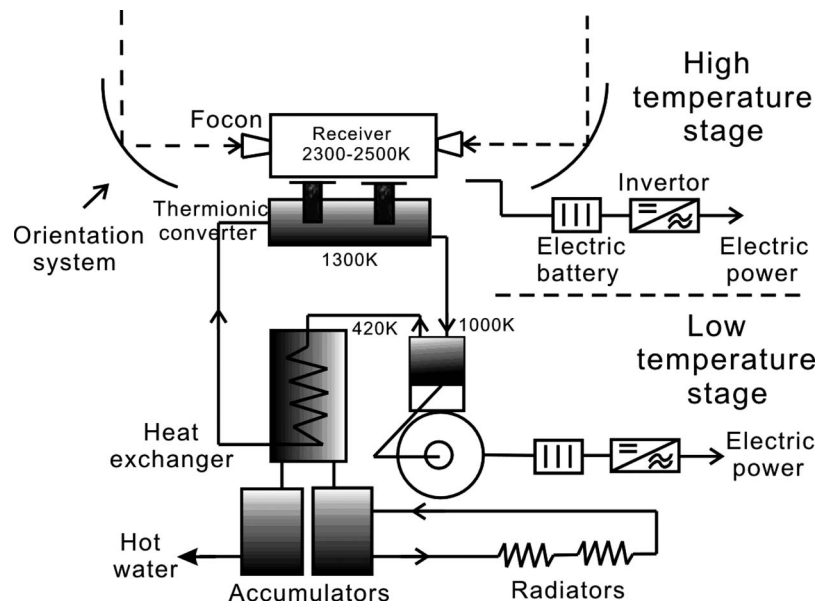

FIG. 16. The schematic of cascade solar cogeneration system. Reprinted with permission from A. Y. Ender, V. I. Kuznetsov, V. I. Sitnov, E. M. Kushner, E. P. Malamed, and D. V. Paramonov, Space Technology and Application International Forum (Albuquerque, 1999). Copyright © 1999, American Institute of Physics.(Ref. 46).

design optimization, as well as temperature uniformity. Therefore, the practical solar thermionic system research still has a long way to go, and a lot of effort is needed to develop highly efficient and practical solar thermionic power generating devices.

C. Magnetohydrodynamic and AMTEC technology

Compared with thermoelectric and thermionic conversion technologies, solar-based MHD and AMTEC power generation technologies have been less studied after the 1990s. This may be due to the following: (1) When compared with thermoelectric and thermionic conversion technologies, although the MHD and AMTEC do not have mechanical moving parts, the working fluid is moving. Thus, the structure is relatively complex and the application is also restricted. (2) For the high-power output direct solar thermal power generation in the space energy field, solar thermionic technology is more favorable for high efficiency and simple structure reasons. (3) As to small-scale thermal power generation application fields, thermoelectric devices are studied the most because they have the simplest structures and are widely commercially available when compared with other power generation methods. In this section, research and recent advances after the 1990s on solar-based MHD and AMTEC technology are reviewed and discussed.

Kaushik *et al.*¹³ reviewed the research and development of solar-assisted liquid metal MHD power generation between the 1960s and 1990s. The solar-assisted liquid metal MHD power generation was compared with traditional power generation methods and the main advantages and disadvantages were demonstrated. In that review, different types of solar-assisted liquid metal MHD power systems were described and the schematic thermal analysis of each component was given. The author concluded that solar-assisted liquid metal MHD power generation was very attractive and could have a promising future, but more effort had to be devoted to the parametric variation studies, cost evaluation, etc., and further research on component optimization and material engineering was very important for its commercialization and utilization.

Liquid metal MHD power generation can be used for a variety of low temperature heat sources, such as solar and waste heat. A basic design of a liquid metal MHD power generator for solar and waste heat was performed by Satyamurthy *et al.*⁴⁸ Considering the system geometric structure and output characteristics, the system was designed to have two cascade loops with loop

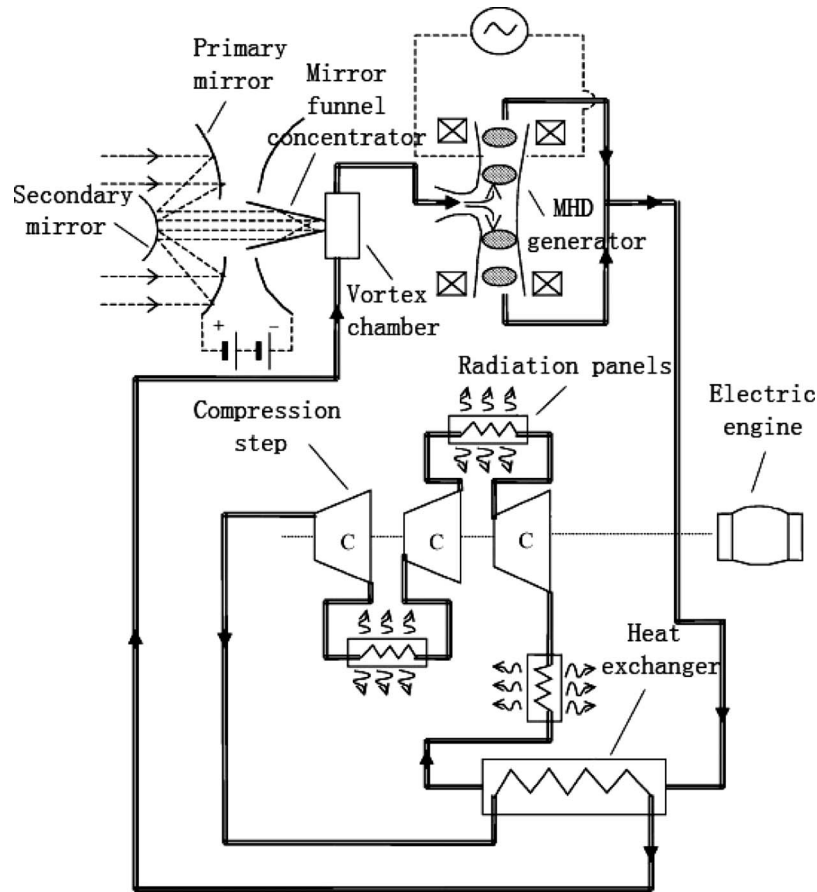

FIG. 18. Schematic of solar MHD power plant. Reprinted with permission from E. P. Chivington, T. L. Hershey, and M. Schuller, *IEEE Trans. Energy Convers.* **21**, 491 (2006). Copyright © 2006, Institute of Electrical and Electronics Engineers.

than a PV system for missions under high radiation environment. However, the pointing and tracking module was more complicated than that of solar-PV system since the solar concentrator was much more sensitive to misalignment.

Another concept of a solar AMTEC power system integrated with advanced global positioning system satellites was developed by Johnson *et al.*⁵¹ The overview of the solar AMTEC power system is shown in Fig. 20. Two symmetric generators which contain parabolic concentrator (reflector) units and solar receivers were designed to produce sufficient electric power from solar heat, and the advanced multitube vapor anode AMTEC cell with 24% conversion efficiency was adopted. The system integration and performance analysis result showed that the solar AMTEC power system is a very good option for space energy supply. The size of the solar AMTEC system was much smaller than that of a solar-PV array and its mass also could be competitive with that

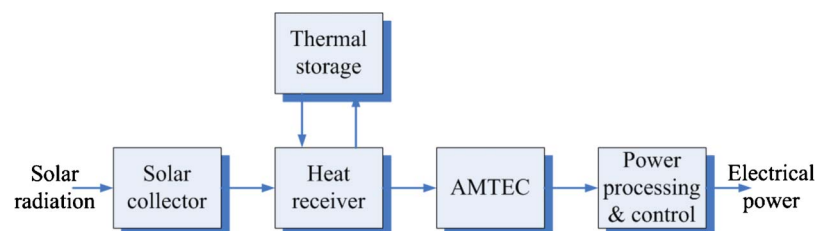

FIG. 19. Schematic of solar heated AMTEC spacecraft power system (Ref. 50).

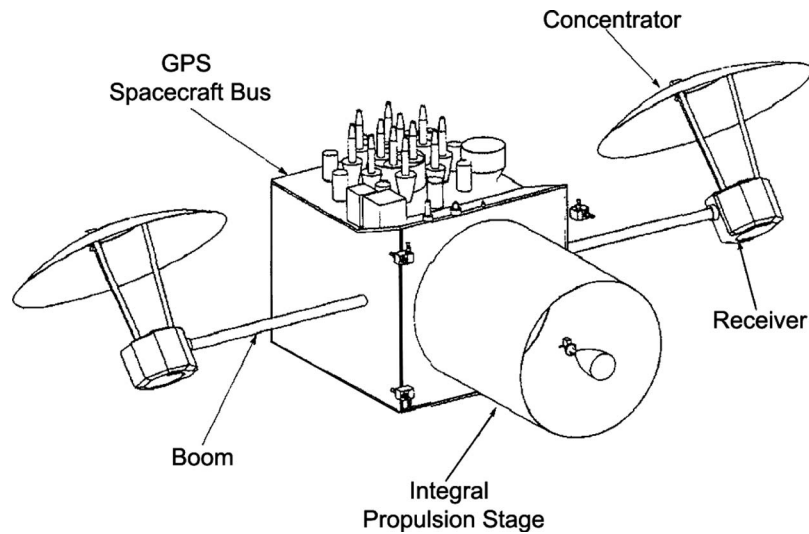

FIG. 20. Schematic of solar AMTEC power system. Reprinted with permission from G. Hohnson, M. E. Hunt, W. R. Deteman, P. A. HoSang, J. Ivanenok, and M. Schuller, *IEEE Aerosp. Electron. Syst. Mag.* **12**, 33 (1997). Copyright © 1997, Institute of Electrical and Electronics Engineers.

of the PV/battery power system. What is more, the solar AMTEC system could be more robust and stable. Therefore, a solar AMTEC power system could be very attractive for space power system.

As to the theoretical design optimization, a sophisticated radial AMTEC cell design parameter methodology was described and analyzed by Hendricks and Huang,⁵² so as to establish optimum design parameters and achieve better cell performance for high-power mission requirements. The design parameter analysis showed that cell efficiency could increase dramatically, with strictly controlled parasitic losses and introduced larger area BASE tubes. It was concluded that a much higher system power could be achieved from the optimum efficiency designs than the maximum power-per-BASE-area designs. The optimum efficiency designs not only had much higher efficiency and produced more system power but could also reduce cell cost and complexity. The design methodology and specific relationships described in that work are meaningful and can help determine optimum high-performance radial AMTEC designs.

D. Cascade system

Apart from independent direct solar thermal power generation methods, cascade systems which combine several power generation methods to obtain higher power output were also widely studied.^{18,20} In general, these cascade systems have much higher efficiency and can make the best of solar heat energy; therefore much higher electric power output can be achieved. However, different stages must match well, especially for the temperature characteristic, so the system design is of crucial importance.

Because the thermionic converter has a very high reject temperature which is very near the input temperature for an AMTEC, it is quite appropriate to achieve higher power output by cascading these two types of converters efficiently.⁵³ A concept of cascaded solar bimodal power system combining both high temperature Cs–Ba thermionic converter and AMTEC was presented by Ender *et al.*⁵⁴ The Cs–Ba thermionic converter could provide a much more suitable temperature environment for the bottoming AMTEC since it had higher optimum collector temperature (1200–1400 K) compared with a conventional Cs thermionic converter, so higher conversion efficiency and smaller system size could be achieved. The optimization and analysis showed that the cascade conversion efficiency in excess of 45% was feasible, which was mainly due to the high efficiency of the Cs–Ba thermionic converter and the suitable operation temperature environment for AMTEC. The author also made an analysis calculation for the Cs–Ba thermionic-thermoelectric

cascade system. It was shown that the efficiency of the Cs–Ba thermionic-AMTEC system could be 7%–8% higher than that of the Cs–Ba thermionic-thermoelectric cascade system. Therefore, a high temperature Cs–Ba thermionic-AMTEC cascade system is very attractive for solar thermal power generation and would allow the development of a highly efficient, compact power system for civilian and military use.

Newman⁵⁵ presented a more complex cascade solar power system which combined four different methods of energy conversion: thermophotovoltaic system, thermionic power generator, alkali-metal thermal electric converter, and methane reformation system. A multilayer half-shell structure was adopted so as to make the best use of the heat energy. In operation, solar radiation was concentrated by lenses and reflectors and then reflected onto the silicon PV cells to produce electricity. Subsequently, part of the waste heat of thermophotovoltaic system was made to operate the thermionic power generator, and then the rejected heat of the thermionic power generator was utilized to operate an alkali-metal thermal electric converter. Finally, a methane reformation system would absorb the rejected heat from the alkali-metal thermal electric converter and the rest of the waste heat of the thermophotovoltaic system to generate hydrogen and carbon monoxide. At night, the stored hydrogen and carbon monoxide would react and produce heat to drive the power system. The overall efficiency was estimated to be as high as 42.6%, which was very attractive for solar power generation.

Apart from thermionic-AMTEC power generation, thermionic-thermoelectric and thermionic-dynamic cascade power generations are also attractive for their good performance. Bevilacqua and Gislou⁵⁶ proposed a solar electric generator combining both thermionic and thermoelectric systems. The whole system consisted mainly of a concentrator, a hollow metal vessel as the radiation receiver, a two-stage thermal electricity conversion system with thermionic and thermoelectric converters as the first and second stages, respectively, and heat drain devices to transfer waste heat to atmosphere. It is said that overall radiation energy into electric efficiency of the order of 30% could be achieved. As to the thermionic-dynamic cascade power generation, it has been previously estimated that the overall efficiency of 32% was reasonable.⁴⁶ Therefore, the cascade power system is very practical and of great value to develop highly efficient solar thermal power system for civil and military use.

III. REMARKS AND FUTURE DEVELOPMENTS

Efficiency and cost are the two most important factors in determining whether or not a solar power generation technology can be applied in large scale. The four individual direct solar thermal power generation technologies as discussed previously might not have evident predominance in the efficiency aspect when compared to solar PV power generation [efficiency of 26% (Ref. 57)] and traditional thermal power generation [efficiency of 30% (Ref. 14)]. However, on the one hand, the direct solar thermal power generation technologies have not been well developed compared with PV or traditional thermal power generation, and their advantage of direct thermal electric conversion without conventional intermediate mechanical energy conversion has not yet been fully developed. On the other hand, the working temperature range of direct thermal power generation technology is relatively wide; thus, the cascade system is feasible and the conversion efficiency could be higher and even go beyond that of traditional methods. Also, the cascade system is not hard to construct, making it very suitable for civilian solar power generation. At present, a lot of literature has shown theoretically that the cascade system is an effective way to fully utilize thermal energy and could improve the overall system efficiency.^{46,53,54} Therefore, we conclude that the potential for direct solar thermal power generation is enormous and the efficiency needs further development.

As to the cost issue, thermoelectric devices have a simple structure and are relatively easy to fabricate. Although with less efficiency, a lot of commercial products are widely used in some flexible and small-scale power generation fields. However, their generation costs are still too high for large-scale power generation,⁵⁸ making them not suitable for practical large-scale solar-based civil use. For MHD power generation, practical large-scale MHD power generation still has some unsolved technical problems and the equipment and experimental costs are expensive.¹⁶ Therefore,

the cost problem is one of the key issues for MHD power generation's large-scale civilian application. As to thermionic conversion, because it has comparatively high efficiency, the energy savings potential and the permissible initial costs could be allowable for acceptance by industry, both in the present and the future.⁵⁹ Finally, for the AMTEC technologies, if the conversion efficiency can be improved and the problems, such as time-dependent degradation behavior, could be solved,²¹ it would seem that the generation cost would be considerable for solar civilian power generation. Present direct thermal power generation technologies do not have predominance in cost, except for some small-scale applications, but they are progressing. How to reduce the generation cost is still the key issue for their large-scale applications.

Finally, preference for solar direct thermal electric conversion lies in that it does not have mechanical moving parts in the power generation module, and therefore can operate stably and silently and have a long working life. This characteristic not only makes it suitable for the military, deep-space exploration, and other fields which have requirements on system stability and noiselessness, but can also reduce the maintenance and operating costs in the civilian power generation applications. Meanwhile, its system structure is compact and flexible, making it especially suitable for some small-scale distributed power generation environments. Therefore, although direct solar thermal electric conversion technologies still have some difficulties in large-scale civilian power generation applications from the perspective of cost and efficiency, they have very good application prospects in small-scale distributed power generation field which has heat energy to utilize. The direct solar thermal power generation technologies have enormous potential, and in order to make full use of their advantages and exploit their potential, the following aspects need to be considered:

- (1) Develop advanced materials to achieve higher thermal electric conversion efficiency. It is believed that a breakthrough in the material field will significantly improve system performance.
- (2) Optimize the structure from both device and system levels. Good design and optimized structure can greatly improve the efficiency of direct solar thermal power generation systems. A lot of research has been performed on optimizing the structure, such as heat recirculation system design and cylindrical thermoelectric structure.^{60,61} In the near future, it can be imagined that micro-/nanofabrication technologies, which combine several different power generation technologies, might effectively improve the device efficiency and output.
- (3) The cascade system has high efficiency and flexible structure and is the most appropriate direct solar thermal power generation method for large-scale civilian applications at present. Therefore, the cascade solar power system should be developed since it is very practical. Moreover, the cascade system could include not only the direct thermal electric converters but also other conventional power generation methods, such as PV cells and so on. It is obvious that the system design and how to make different stages match are of great importance.
- (4) We attach great importance to applications in small-scale distributed power generation field. Direct solar thermal power generation technology has a simple structure and good flexibility and scalability. Therefore, attention should be paid to the small-scale distributed power generation applications, such as the power supply in remote mountainous areas and residential energy supply areas. Portable applications could also try to utilize the direct solar thermal power system as the power supply.

IV. CONCLUSION

This paper comprehensively reviews the recent advances in direct solar thermal power generation technologies. It can be seen that although much effort has been made to develop these technologies, the conversion potential and practical applications are still not widely used. In order to make full use of its advantages and develop practical civil devices, more effort should be devoted to material research, structure optimization, and practical application development. Ob-

viously, all these efforts need cooperation among physicists, chemists, material scientists, and engineers. The global needs for sustainable and green energy inspire great excitement in the field.

- ¹ Q. Y. Ni, *Science & Technology Review* **5**, 63 (1996).
- ² G. J. Snyder and E. S. Toberer, *Nature Mater.* **7**, 105 (2008).
- ³ I. B. Cadoff and E. Miller, *Thermoelectric Materials and Devices* (Reinhold, New York, 1960).
- ⁴ S. B. Riffat and X. L. Ma, *Appl. Therm. Eng.* **23**, 913 (2003).
- ⁵ T. Caillat, J. P. Fleurial, G. J. Snyder, and A. Borshchevsky, 20th International Conference on Thermoelectrics (IEEE, Beijing, 2001), p. 282.
- ⁶ L. E. Bell, *Science* **321**, 1457 (2008).
- ⁷ H. X. Xi, L. G. Luo, and G. Fraisse, *Renewable Sustainable Energy Rev.* **11**, 923 (2007).
- ⁸ V. I. Babanin, A. Y. Ender, I. N. Kolyshkin, V. I. Kuznetsov, V. I. Sitnov, and D. V. Paramonov, Proceedings of the 32nd Intersociety Energy Conversion Engineering Conference (American Institute of Chemical Engineers, Honolulu, 1997), p. 427.
- ⁹ T. F. Zeng, *Appl. Phys. Lett.* **88**, 153104 (2006).
- ¹⁰ G. N. Hatsopoulos and E. P. Gyftopoulos, *Thermionic Energy Conversion* (MIT Press, Cambridge, 1973).
- ¹¹ Y. V. Nikolaev, A. S. Gontar, S. A. Eriomin, O. L. Izhvanov, S. S. Kalmykov, Y. D. Karpechenko, V. S. Kolesov, V. U. Koroliev, R. Y. Kucherov, N. V. Lapochkin, T. Lechtenberg, and L. Begg, *Space Technology and Applications International Forum* (American Institute of Physics, Albuquerque, 1999), p. 1581.
- ¹² H. Yamaguchi, X. R. Zhang, S. Higashi, and M. J. Li, *J. Magn. Magn. Mater.* **320**, 1406 (2008).
- ¹³ S. C. Kaushik, S. S. Verma, and A. Chandra, *Heat Recovery Syst. CHP* **15**, 675 (1995).
- ¹⁴ C. X. Ju, Y. C. Lv, and B. H. Jing, *Open Cycle MHD Power Generation* (Beijing University of Technology Press, Beijing, 1998) (in Chinese).
- ¹⁵ H. Branover, A. Yakhot, and A. El-Boher, Seventh International Conference on MHD Electrical Power Generation (Massachusetts Institute of Technology (MIT) & Symposia on the Engineering Aspects of Magnetohydrodynamics (SEAM) Inc., Boston, 1980), p. 165.
- ¹⁶ N. Kayukawa, *Prog. Energy Combust. Sci.* **30**, 33 (2004).
- ¹⁷ N. Kayukawa, *Energy Convers. Manage.* **41**, 1953 (2000).
- ¹⁸ M. A. K. Lodhi and A. Mustafa, *J. Power Sources* **158**, 740 (2006).
- ¹⁹ M. A. K. Lodhi and J. B. Briggs, *J. Power Sources* **168**, 537 (2007).
- ²⁰ M. S. El-Genk and J. M. P. Tournier, *Energy Convers. Manage.* **45**, 511 (2004).
- ²¹ M. A. K. Lodhi, P. Vijayaraghavan, and A. Daloglu, *J. Power Sources* **96**, 343 (2001).
- ²² L. F. Zhang and B. Li, *Energy Technology* **25**, 114 (2004) (in Chinese).
- ²³ M. S. El-Genk and J.-M. Tournier, *Energy Convers. Manage.* **43**, 1931 (2002).
- ²⁴ N. Hiroyuki and N. Akira, Japan Patent No. JP2001153470-A (June 8, 2001).
- ²⁵ S. A. Omer and D. G. Infield, *Energy Convers. Manage.* **41**, 737 (2000).
- ²⁶ J. C. Chen, *J. Appl. Phys.* **79**, 2717 (1996).
- ²⁷ B. Lenoir, A. Dauscher, P. Poinas, H. Scherrer, and L. Vikhor, *Appl. Therm. Eng.* **23**, 1407 (2003).
- ²⁸ S. Maneewan, J. Hirunlabh, J. Khedari, B. Zeghmami, and S. Teekasap, *Sol. Energy* **78**, 495 (2005).
- ²⁹ S. Maneewan, J. Khedari, B. Zeghmami, J. Hirunlabh, and J. Eakburanawat, *Renewable Energy* **29**, 743 (2004).
- ³⁰ N. M. Khattab and E. T. El Shenawy, *Energy Convers. Manage.* **47**, 407 (2006).
- ³¹ J. A. Micallef, U.S. Patent No. US2008053514-A1 (March 6, 2008).
- ³² H. Berke and R. Gaudiana, U.S. Patent No. US2006225782-A1 (October 12, 2006).
- ³³ R. D. Hunt, Patent No. WO2004004016-A1 (January 8, 2004).
- ³⁴ D. H. Hecht, U.S. Patent No. US2007289622-A1 (December 20, 2007).
- ³⁵ S. Masayuki, K. Katsuhito, F. Kazuhisa, and S. Kazuyuki, Japan Patent No. JP2005093449-A (April 7, 2005).
- ³⁶ R. Robert, S. Romer, A. Reller, and A. Weidenkaff, *Adv. Eng. Mater.* **7**, 303 (2005).
- ³⁷ R. Robert, L. Bocher, B. Sipos, M. Dobeli, and A. Weidenkaff, *Prog. Solid State Chem.* **35**, 447 (2007).
- ³⁸ S. F. Adams, *Space Technology and Applications International Forum* (American Institute of Physics, Albuquerque, 2006), p. 590.
- ³⁹ B. G. Ogloblin, E. Y. Kirillov, A. V. Klimov, A. I. Shalaev, D. P. Shumov, A. Y. Ender, V. I. Kuznetsov, and V. I. Sitnov, *Space Technology and Applications International Forum (STAIF-96)* (American Institute of Physics, Albuquerque, 1996), p. 1459.
- ⁴⁰ H. H. Streckert, L. L. Begg, Y. V. Nikolaev, D. L. Tsetschlads, S. A. Eriomin, O. L. Izhvanov, and N. V. Lapochkin, *Space Technology and Applications International Forum* (American Institute of Physics, Albuquerque, 2000), p. 1302.
- ⁴¹ M. R. Martinez, O. Izhvanov, B. Robertson, P. N. Clark, H. H. Streckert, and J. L. Desplat, *Space Technology and Applications International Forum* (American Institute of Physics, Albuquerque, 2005), p. 926.
- ⁴² H. Streckert, D. Peltier, L. Begg, and J. Watson, *Space Technology and Applications International Forum* (American Institute of Physics, Albuquerque, 2002), p. 1028.
- ⁴³ W. Zheng, A. Ogino, and H. Kando, *Jpn. J. Appl. Phys., Part 1* **39**, 2816 (2000).
- ⁴⁴ S. Masashi, Japan Patent No. JP2002078364-A (March 15, 2002).
- ⁴⁵ P. N. Clark, J. L. Desplat, H. H. Streckert, S. F. Adams, and J. W. Smith, *Space Technology and Applications International Forum* (American Institute of Physics, Albuquerque, 2006), p. 598.
- ⁴⁶ A. Y. Ender, V. I. Kuznetsov, V. I. Sitnov, E. M. Kushner, E. P. Malamed, and D. V. Paramonov, *Space Technology and Applications International Forum* (American Institute of Physics, Albuquerque, 1999), p. 1408.
- ⁴⁷ H. Fowler and A. Israel, U.S. Patent No. US4168716-A (September 25, 1979).
- ⁴⁸ P. Satyamurthy, N. Venkatramani, A. M. Quraishi, and A. Mushtaq, *Energy Convers. Manage.* **40**, 913 (1999).
- ⁴⁹ V. S. Slavin, G. C. Bakos, T. A. Milovidova, and K. A. Fennikov, *IEEE Trans. Energy Convers.* **21**, 491 (2006).
- ⁵⁰ E. P. Chivington, T. L. Hershey, and M. Schuller, 29th Intersociety Energy Conversion Engineering Conference (American Institute of Aeronautics and Astronautics, Monterey, 1994), p. 300.

- ⁵¹G. Johnson, M. E. Hunt, W. R. Determan, P. A. HoSang, J. Ivanenok, and M. Schuller, *IEEE Aerosp. Electron. Syst. Mag.* **12**, 33 (1997).
- ⁵²T. J. Hendricks and C. D. Huang, *J. Sol. Energy Eng.* **122**, 49 (2000).
- ⁵³T. H. VanHagan, J. N. Smith, and M. Schuller, *IEEE Aerosp. Electron. Syst. Mag.* **12**, 10 (1997).
- ⁵⁴A. Y. Ender, I. N. Kolyshkin, V. I. Kuznetsov, E. V. Yakovlev, and D. V. Paramonov, *Space Technology and Applications International Forum* (American Institute of Physics, Albuquerque, 1998), p. 1565.
- ⁵⁵E. Newman, U.S. Patent No. US5518554-A (May 21, 1996).
- ⁵⁶S. Bevilacqua and R. Gislou, U.S. Patent No. US4257823-A (March 24, 1981).
- ⁵⁷R. McConnell, *Refocus* **6**, 35 (2005).
- ⁵⁸L. Jia, Ph.D. thesis, University of Science and Technology of China, 2006.
- ⁵⁹M. Kocoloski, C. Eger, R. McCarty, K. Hallinan, and K. Kissock, *ACEEE Summer Study on Energy Efficiency in Industry* (ACEEE, New York, 2007), p. 55.
- ⁶⁰G. Min and D. M. Rowe, *IEEE Trans. Energy Convers.* **22**, 528 (2007).
- ⁶¹S. A. Whalen, C. A. Apblett, and T. L. Aselage, *J. Power Sources* **180**, 657 (2008).